

# Step Lite Square

Cat. No. SLsq  
Cat. No. SLflsq



Step Lite is designed with a 88mm x 88mm (3½" x 3½") flange for flush mounting into masonry, stone or wood. This luminaire is ideal for illumination of steps and ground level horizontal lighting, for example, across driveways or exterior paved areas. When a canister is used there are no mounting holes in the flange.

A 110/240 volt fluorescent option is available which offers excellent light output, low energy usage and very low heat generation, this changes the luminaire to an IP66 rating.

## Ordering Information

### Luminaire Type

SLsq - Step Lite Square

### Material/Finish

BK - Black  
BZ - Bronze  
GN - Green  
STAR - Silver Star  
WH - White  
CP - Copper  
SS - 316 Stainless

### Accessories

CJK150 - Cable Joint Kit  
LENSSTEPF - Frosted Lens  
FL - Fluorescent Option  
HCL - Hex Cell Louvre Adaptor  
Canss - 316 Stainless Steel Canister  
Flucan - Fluorescent Canister  
Slcan - Step Lite Canister  
For an alternative LED option start at page 10.4

Ordering Example: SLsq BZ - Step Lite Square in bronze powder coat.

SLflsq SS - Step Lite Square with Fluorescent Option in 316 Stainless Steel

HCL BK - Hex Cell Louvre Adaptor in black  
(Accessories ordered separately)

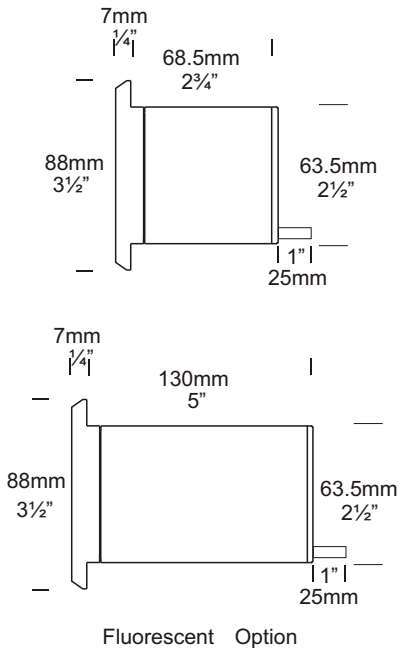

**HUNZA**™ PURE OUTDOOR LIGHTING

**HUNZA FACTORY**  
130 Felton Mathew Ave  
Glen Innes  
Auckland 1072  
New Zealand

Ph: 64-9-528 9471  
Fax: 64-9-528 9361  
hunza@hunza.co.nz  
www.hunza.co.nz

**INTERNATIONAL CONTACTS:**  
www.hunza.co.nz/contacts.php

Specifications may change without notice.  
Manufactured in New Zealand.  
© 2009 Hunza Holdings Ltd.

Ver 1.4

## Luminaire Construction

CNC machined from one of the following metals:

High corrosion resistant 63.5mm (2½") x 10mm (25/64") aluminium. End cap - solid aluminium 63.5mm (2½") rod, flange 90mm x 90mm (3½" x 3½") solid aluminium bar with chromate substrate and high UV resistant polyester powder coat

**Colours** Black, Bronze, Green, Silver Star, White.

**Copper:** 63.5mm (2½") x 10.5mm (13/32"). End cap - solid copper 63.5mm (2½") rod. Flange 90mm x 90mm (3½" x 3½") solid copper bar.

**316 Stainless steel:** 9mm (11/32"). End cap - solid 316 stainless steel 63.5mm (2½") bar. Flange 90mm x 90mm (3½" x 3½") solid 316 stainless steel bar.

## Mounting

Designed to fit through a 66mm (2 5/8") hole and be fixed into position by two screws in the flange or a Step Lite canister (see accessories) can be used which maintains the aesthetic look of the flange by eliminating the two screw holes in the flange.

## Features

**Lens:**  
10mm (3/8") thick clear 'flush fit' tempered shatter resistant glass.  
Life Time Warranty.

**Gaskets:**  
Silicone, iron impregnated 220°C (428°F).

**Lamp Holders:**  
GU5.3 - 350°C (662°F) ceramic multi contact lamp holder with 250°C (480°F) teflon cables.

**Fluorescent:**  
E27 PET 210°C (410°F) base mount.  
E26 available in the USA.

## Accessories:

Cable Joint Kit (Cat. CJK150)  
Not approved for USA /Canada.

Fluorescent Option 8watt 240 volt (Cat. FL) IP66.

Frosted Lens (Cat. LENSSTEPF).

Hex Cell Louvre Adaptor (Cat. HCL).

Step Canister (Cat. Slcan).

Fluorescent Canister, PVC (Cat. Flucan).

316 Stainless Canister for use in lime stone etc. (Cat. Canss).

## Standards

EN60598

IP66/IP68



UL1838

## Luminaire Weight

12 volt

Alum .465kg (1lb)

Cop 1.340kg (2lb 15oz)

SS 1.055kg (2lb 5oz)

Fluorescent IP66

Alum .780kg (1lb 11oz)

Cop 2.275kg (5lb)

SS 1.690kg (3lb 11oz)

## Power Supply

HUNZA™ Inground or Wall Mount  
Transformer: not included.

USA and Canada:

HUNZA™ Wall Mount Transformer:  
not included.

Luminaire: supplied with

Halogen

MR16 GU5.3 20 watt lamp max.

Fluorescent

E27 - 110/240 volt self ballasted  
lamp.

LED

LED - Refer sheet no. 10.4

USA and Canada:

MR16 GU5.3 20 watt lamp max.

LED

LED - Refer sheet no. 10.4

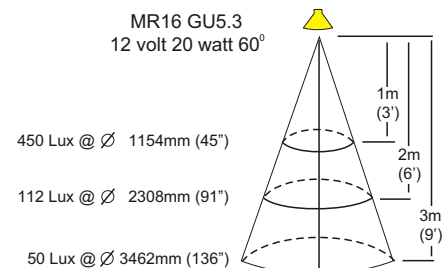
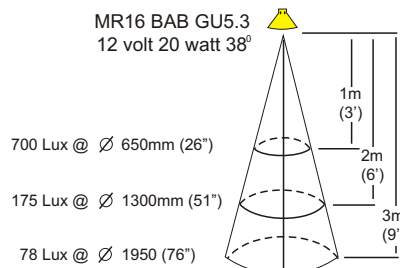
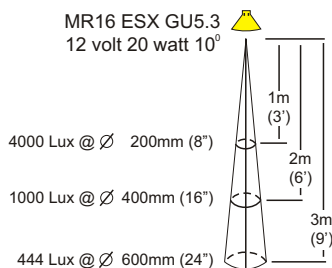

**HUNZA™** PURE  
OUTDOOR  
LIGHTING

**HUNZA FACTORY**  
130 Felton Mathew Ave  
Glen Innes  
Auckland 1072  
New Zealand

Ph: 64-9-528 9471  
Fax: 64-9-528 9361  
hunza@hunza.co.nz  
www.hunza.co.nz

**INTERNATIONAL CONTACTS:**  
www.hunza.co.nz/contacts.php

Specifications may change without notice.  
Manufactured in New Zealand.

© 2009 Hunza Holdings Ltd.

Ver 1.4