

GE ConstantColor CMH™ Precise™ MR16 20 & 35W

LAMP TECHNOLOGY

ConstantColor CMH™ lamps combine HPS technology (providing stability, efficiency & uniformity) and Metal Halide Technology (providing bright white quality light) to produce highly efficient light sources with good colour rendering and consistent colour performance through life. This is achieved by using the ceramic arc tube material from the Lucalox™ lamp, which minimises the chemical changes inside the lamp through life.

GE has now miniaturized this technology resulting in the CMH™ Precise™ MR16, highly efficient 20 & 35 Watt lamps with the light quality and colour stability associated with Ceramic Metal Halide, in a size comparable to tungsten halogen reflector lamps, thus offering new energy saving options to the lighting designer and end user.



FEATURES

- Consistent colour over life
- Excellent colour uniformity lamp to lamp
- Bright light – in a very compact size
- Excellent colour rendition
- High reliability due to 3 part ceramic design
- Up to 54 beam Lumens per Watt (LPW) efficacy
- Long Life
- UV control
- 35W available in two colour temperatures
- Robust GX10 base

APPLICATION AREAS

- Retail
- Offices
- Outdoor Lighting
- Display Cabinet
- Hotels

Watts	Operating position	Length mm	Order Code	Cap	Colour	CBCP (cd)	Rated Average Life hrs.	Pack Qty	Product Code
20	U	54.5	CMH20/MR16/UVC/830/GX10/SP	GX10	830	9000	12000	12	40400
20	U	54.5	CMH20/MR16/UVC/830/GX10/FL	GX10	830	2900	12000	12	40401
20	U	54.5	CMH20/MR16/UVC/830/GX10/WFL	GX10	830	1500	12000	12	42691
35	U	54.5	CMH35/MR16/UVC/930/GX10/SP	GX10	930	16000	10000*	12	88658
35	U	54.5	CMH35/MR16/UVC/930/GX10/FL	GX10	930	5500	10000*	12	88659
35	U	54.5	CMH35/MR16/UVC/930/GX10/WFL	GX10	930	3000	10000*	12	88660
35	U	54.5	CMH35/MR16/UVC/942/GX10/SP	GX10	942	16000	12000*	12	88661
35	U	54.5	CMH35/MR16/UVC/942/GX10/FL	GX10	942	5500	12000*	12	88662
35	U	54.5	CMH35/MR16/UVC/942/GX10/WFL	GX10	942	3000	12000*	12	88663

* Initial rating at time of launch. Testing continues to establish final design life.



General

Product code	40400	40401	42691	88658	88659	88660	88661	88662	88663
Nominal wattage	20W	20W	20W	35W	35W	35W	35W	35W	35W
Format	MR16	MR16	MR16	MR16	MR16	MR16	MR16	MR16	MR16
Bulb type	MR16	MR16	MR16	MR16	MR16	MR16	MR16	MR16	MR16
Bulb diameter	51 mm	51 mm	51 mm	51 mm	51 mm	51 mm	51 mm	51 mm	51 mm
Bulb material	Borosilicate glass	Borosilicate glass	Borosilicate glass	Borosilicate glass	Borosilicate glass	Borosilicate glass	Borosilicate glass	Borosilicate glass	Borosilicate glass
Bulb finish	Aluminized	Aluminized	Aluminized	Aluminized	Aluminized	Aluminized	Aluminized	Aluminized	Aluminized
Arc Gap	N/A	N/A	N/A	N/A	N/A	N/A	N/A	N/A	N/A
Base	GX10	GX10	GX10	GX10	GX10	GX10	GX10	GX10	GX10

Operating Conditions

Burning Pos'n	Universal	Universal	Universal	Universal	Universal	Universal	Universal	Universal	Universal
Luminaire	Open	Open	Open	Open	Open	Open	Open	Open	Open

Electrical Characteristics

Power	20W	20W	20W	39W	39W	39W	39W	39W	39W
Voltage	95V	95V	95V	90V	90V	90V	90V	90V	90V
Current	0.21A	0.21A	0.21A	0.42A	0.42A	0.42A	0.42A	0.42A	0.42A
Max ignition voltage	4kV	4kV	4kV	5kV	5kV	5kV	5kV	5kV	5kV
Min ignition voltage	3kV	3kV	3kV	3kV	3kV	3kV	3kV	3kV	3kV
Extinction voltage	80%	80%	80%	90%	90%	90%	90%	90%	90%

Photometric characteristics

Beam Angle	12° Spot	25° Flood	40° Wide Flood	12° Spot	25° Flood	40° Wide Flood	12° Spot	25° Flood	40° Wide Flood
CBCP	9000	2900	1500	16000	5500	3000	16000	5500	3000
lumens	1000	1000	1000	2100	2100	2100	2100	2100	2100
CCT	3000K	3000K	3000K	3000K	3000K	3000K	4000K	4000K	4000K
CCx	0.431	0.431	0.431	0.444	0.444	0.444	0.383	0.383	0.383
CCy	0.403	0.403	0.403	0.401	0.401	0.401	0.370	0.370	0.370
CRI	81	81	81	90	90	90	92	92	92
Luminous efficacy	50 LPW	50 LPW	50 LPW	54 LPW	54 LPW	54 LPW	54 LPW	54 LPW	54 LPW

Starting and Warm-up Characteristics

Time to start @ 10C, sec	<5	<5	<5	<5	<5	<5	<5	<5	<5
Time to start @ -15C, sec	<15	<15	<15	<15	<15	<15	<15	<15	<15
Hot restart time, min	<4	<4	<4	<6.5	<6.5	<6.5	<6.5	<6.5	<6.5
Warm-up to time to 90% lumen output, min	<1.5	<1.5	<1.5	<1.5	<1.5	<1.5	<1.5	<1.5	<1.5

Maximum Operating Condition

Max bulb temperature ¹	200°C	200°C	200°C	300°C	300°C	300°C	300°C	300°C	300°C
Max base temperature ²	200°C	200°C	200°C	300°C	300°C	300°C	300°C	300°C	300°C

¹ Measured at centre of MR16 lens, in vertical base-up position² Measured on 25mm GX10 ceramic cap rim, at transition to 23mm diameter

Dimensions

	40400	40401	42691	88658	88659	88660	88661	88662	88663
A (max), mm	54.5	54.5	54.5	54.5	54.5	54.5	54.5	54.5	54.5
B (max), mm	51	51	51	51	51	51	51	51	51
C (max), mm	3.5	3.5	3.5	3.5	3.5	3.5	3.5	3.5	3.5
D (max), mm	14	14	14	14	14	14	14	14	14

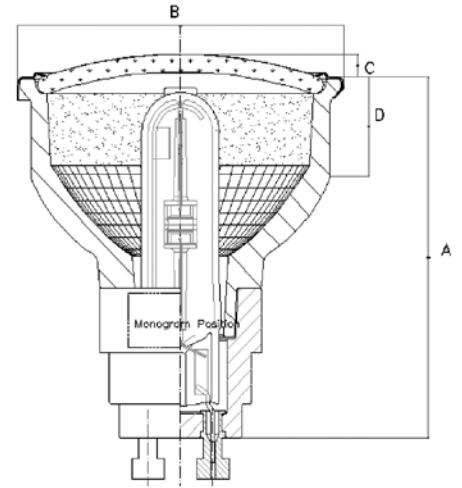

Spectral Power Distribution

Spectral Power Distribution curve is given in the following diagram

Spectral Power Distribution CMH20MR16/830

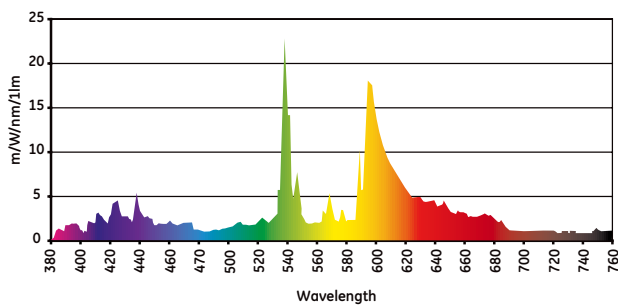

Spectral Power Distribution CMH35MR16/930

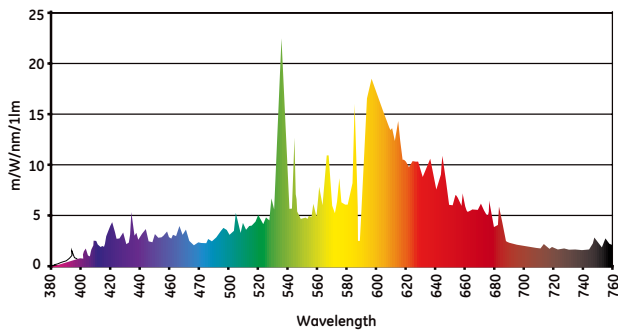

Spectral Power Distribution CMH35MR16/942

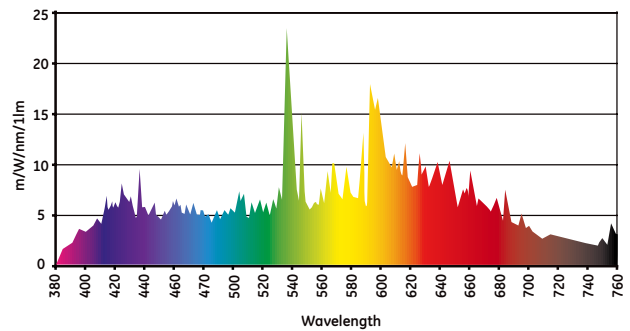

Distribution of luminous intensity

The following diagrams show polar light intensity curves and beam diagrams for vertical base-up orientation

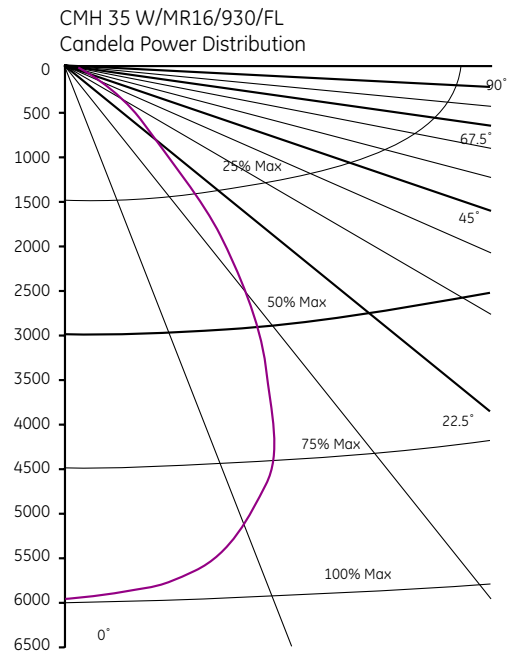
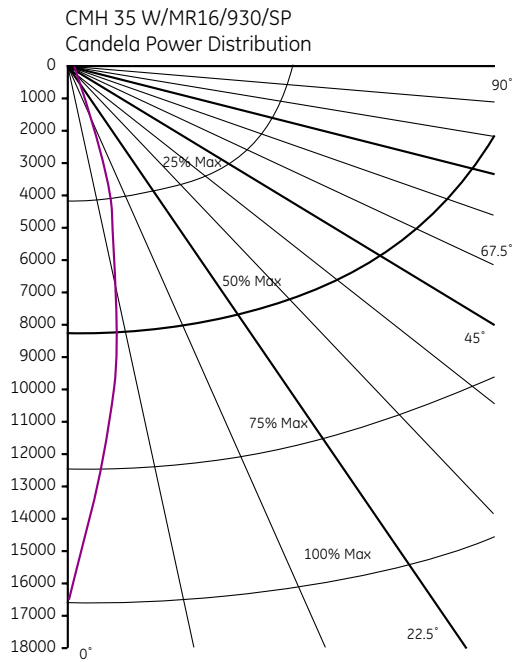
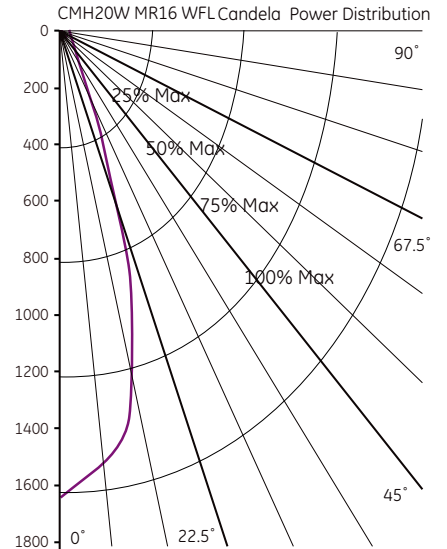
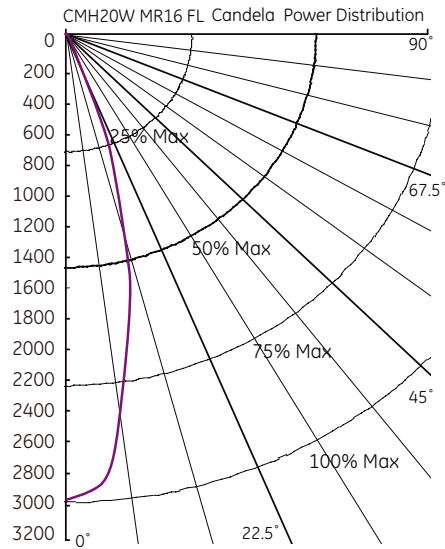
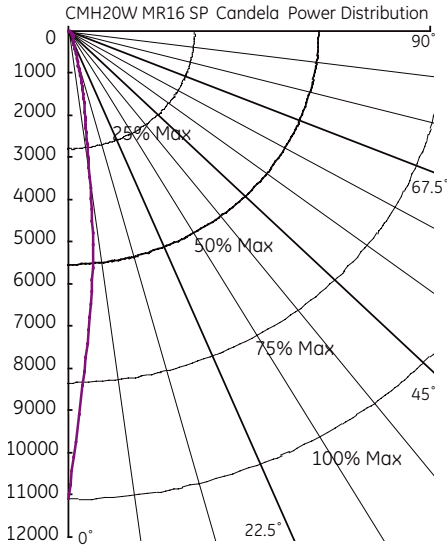

CMH 35 W/MR16/930/WFL
Candela Power Distribution

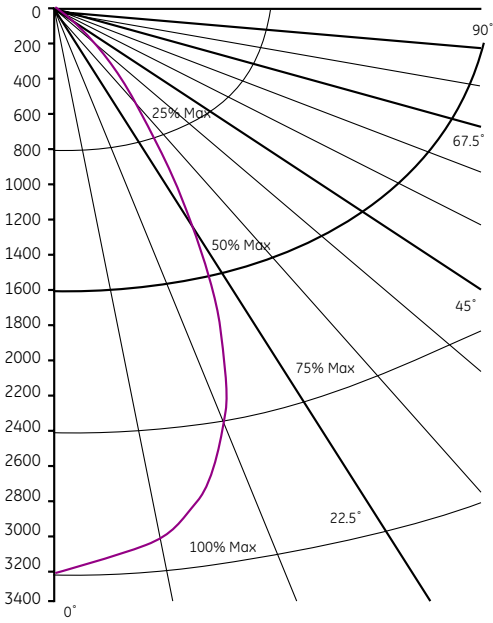

CMH 35 W/MR16/942/SP
Candela Power Distribution

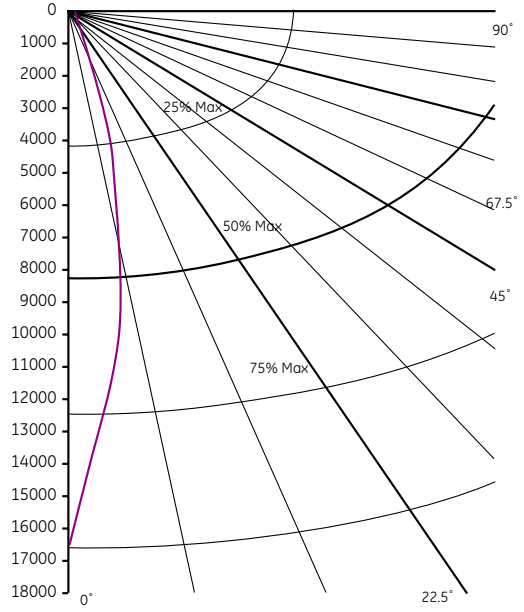

CMH 35 W/MR16/942/FL
Candela Power Distribution

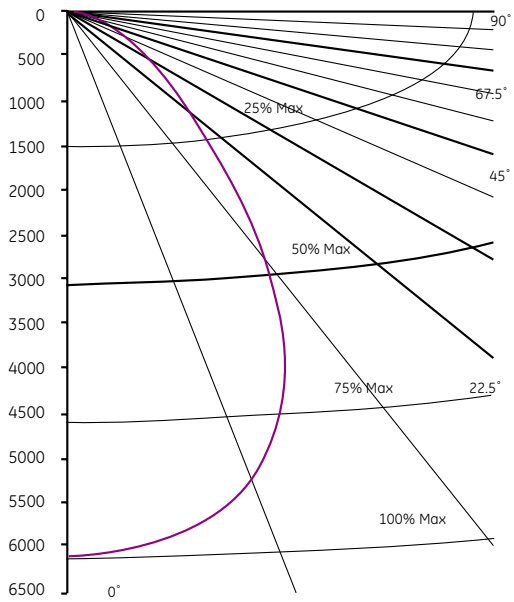

CMH 35 W/MR16/942/WFL
Candela Power Distribution

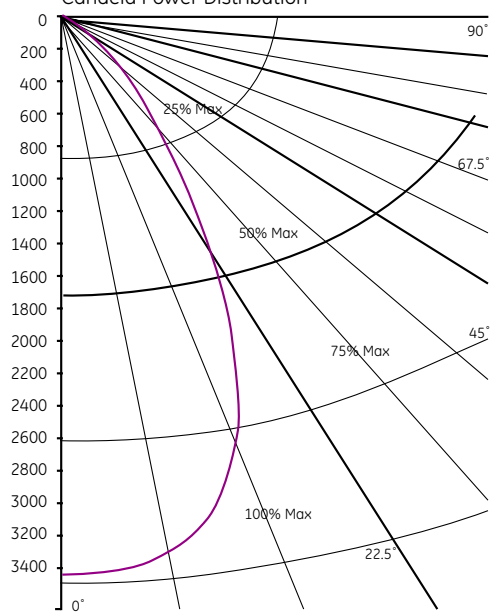

Beam diagrams

CMH20/MR16/UVC/830/GX10/SP

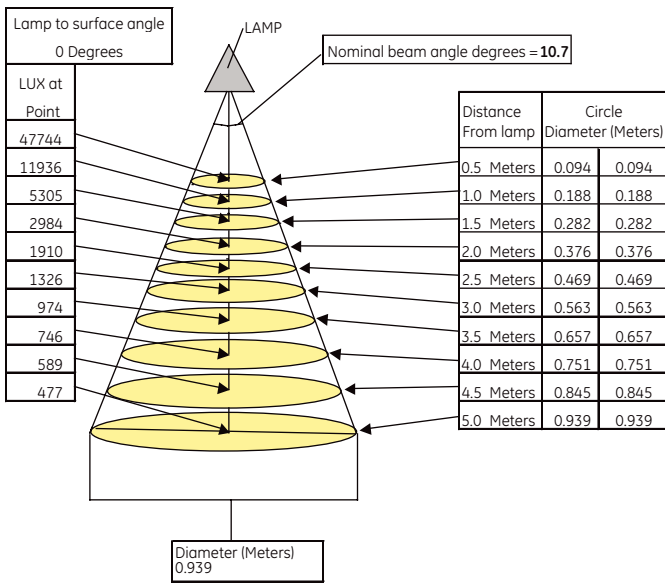

CMH20/MR16/UVC/830/GX10/FL

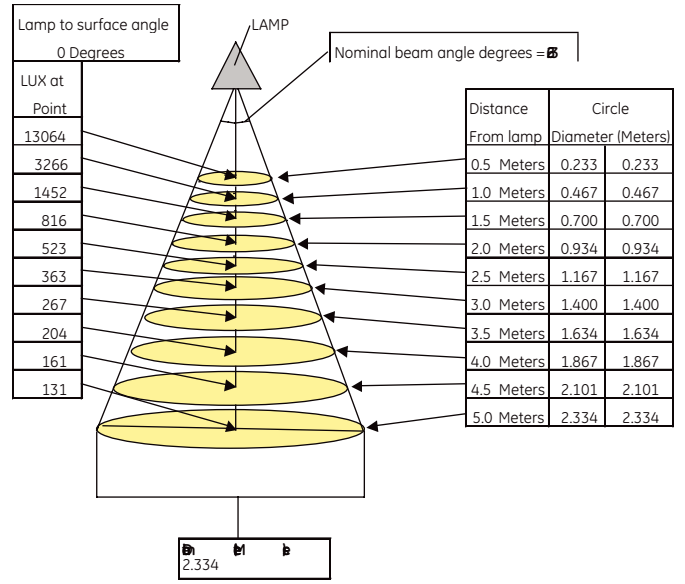

CMH20/MR16/UVC/830/GX10/WFL

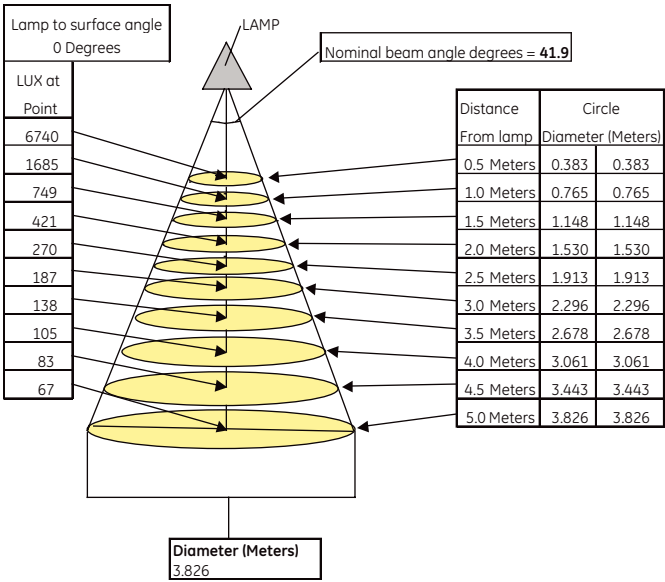

CMH35/MR16/UVC/930/GX10/SP

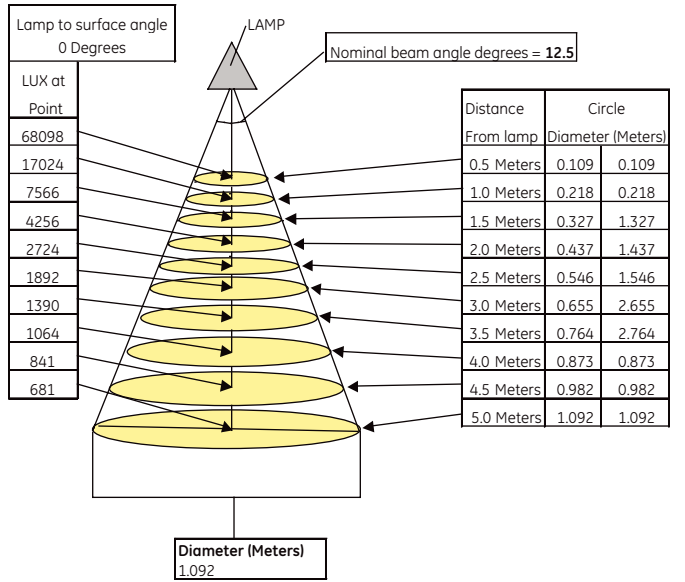

CMH35/MR16/UVC/930/GX10/FL

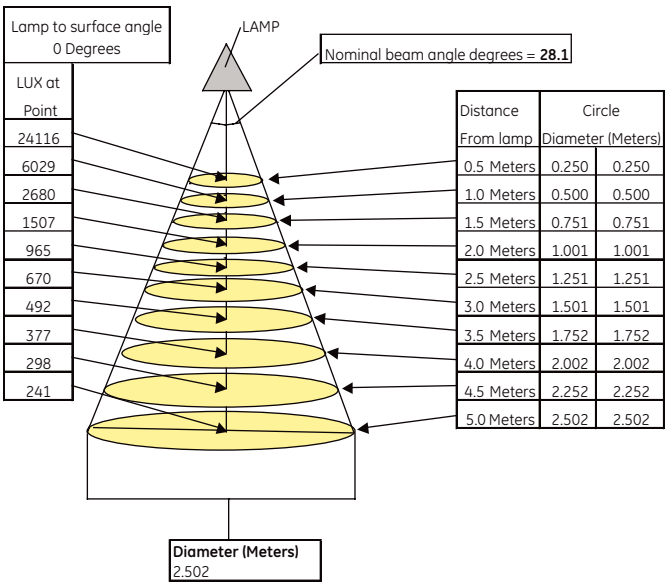

CMH35/MR16/UVC/930/GX10/WFL

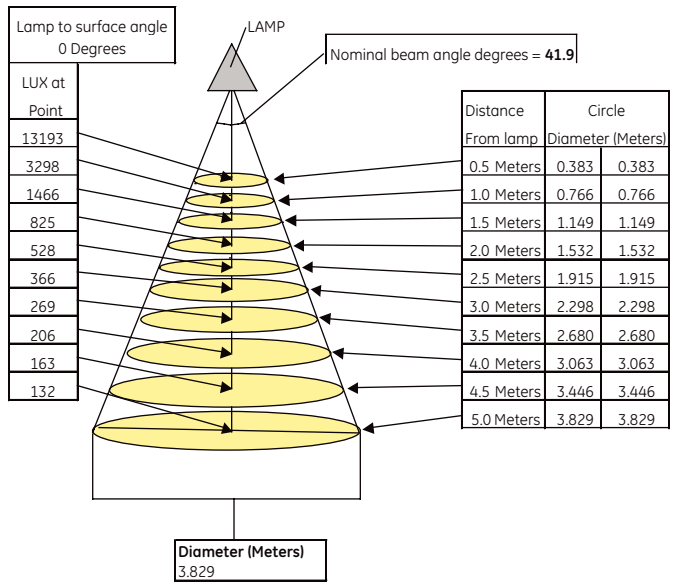

CMH35/MR16/UVC/942/GX10/SP

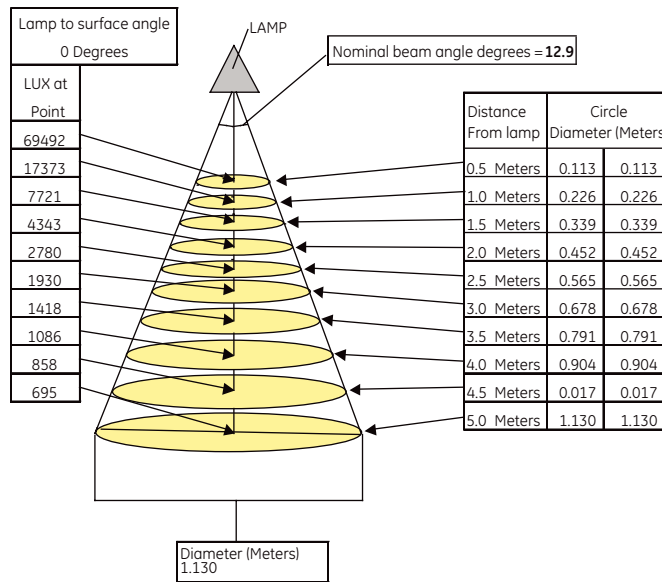

CMH35/MR16/UVC/942/GX10/FL

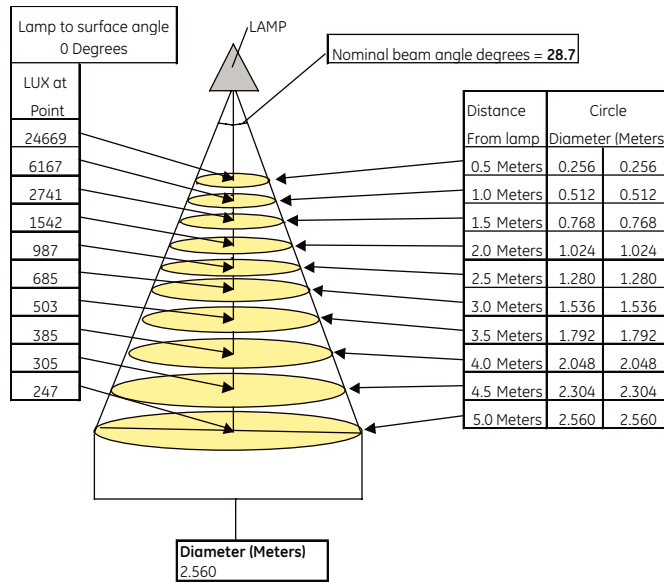

CMH35/MR16/UVC/942/GX10/WFL

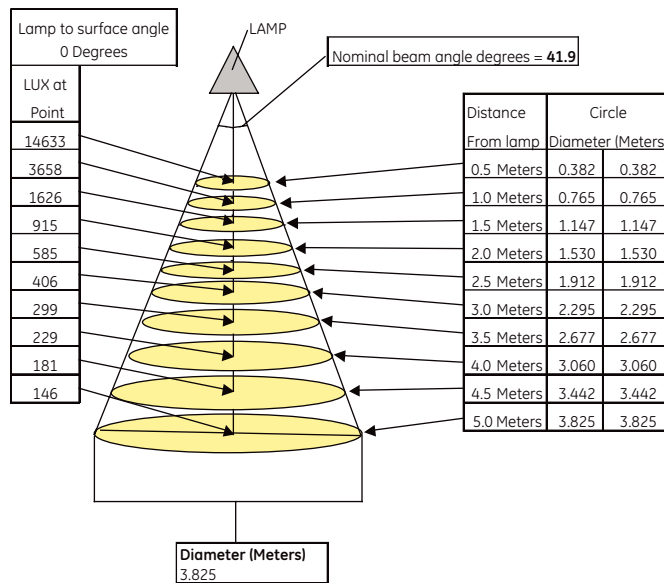

Lamp life

Life survival graphs are shown for statistically representative batches of lamps operated under controlled nominal conditions with a 11 hours per start switching cycle. Declared lamp life is the median value, i.e. when 50% of lamps from a large sample batch would have failed. Lamp life in service is affected by a number of parameters, including supply voltage variation, switching cycle, operating position, ballast impedance tolerance, luminaire design and mechanical vibration.

The information provided is intended to be a practical guide for comparison with other lamp types. Determination of lamp replacement schedules will depend upon relative costs of spot or group replacement and acceptable reduction in lighting levels.

Note: Representative curves are shown for Vertical Base-Up lamp orientation unless otherwise specified. Life performance increases in the Horizontal burning position.

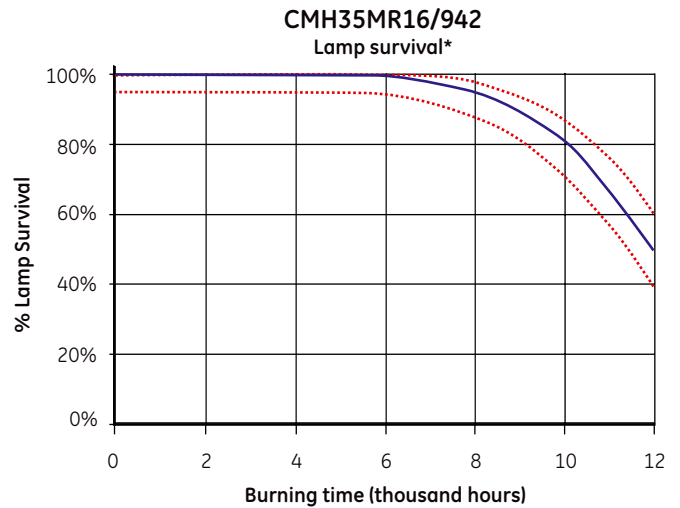
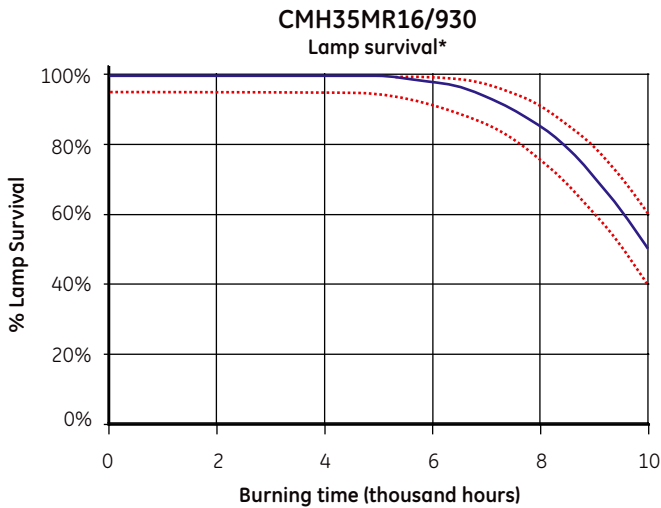
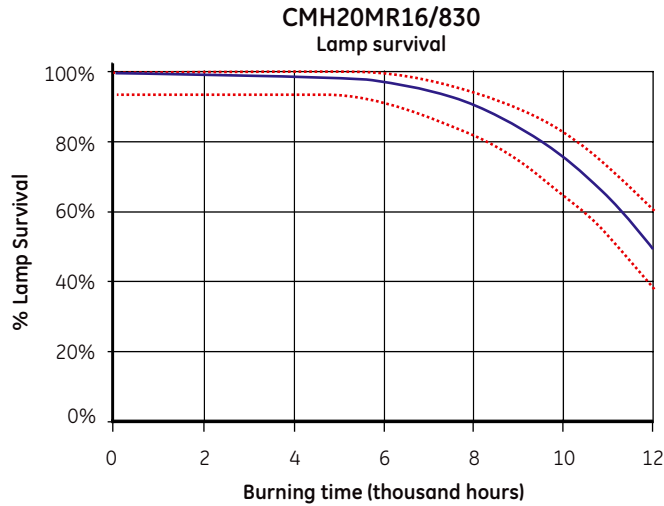

* Initial rating at time of launch. Testing continues to establish final design life.

Lumen maintenance

Lumen maintenance graphs show light output performance through life for statistically representative batches of lamps operated under controlled nominal conditions with a 11 hours per start switching cycle.

A common characteristic for all metal halide lamps is a reduction in light output and a slight increase in power consumption through life. Consequently there is an economic life at which lamp efficacy falls to a level when lamps should be replaced to restore design illumination levels. Where a quantity of lamps are installed within an area, consideration should be given to a group lamp replacement programme to maintain uniform illumination levels.

Curves represent operating conditions for a 11 hours per start switching cycle, but less frequent switching will improve lumen maintenance.

Note: The representative curves are shown for Vertical Base-Up lamp orientation unless otherwise specified. Lumen maintenance performance improves when operated in the Horizontal burning position.

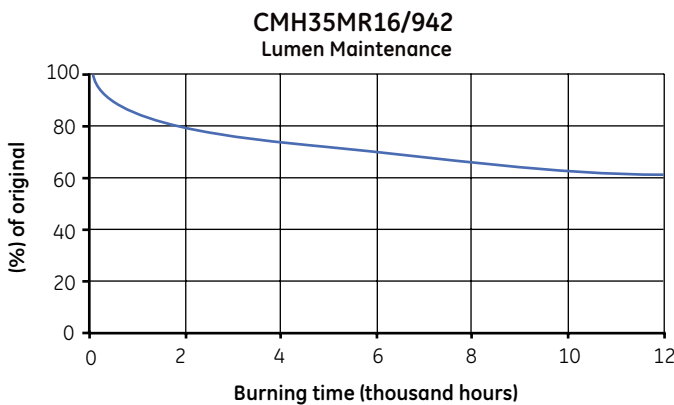
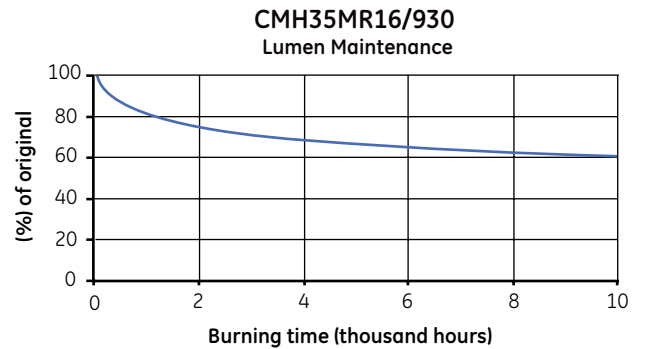
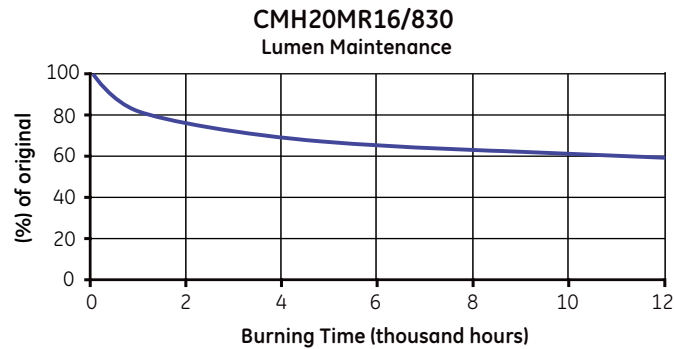

Warm-up characteristics

During the warm-up period immediately after starting, lamp temperature increases rapidly evaporating mercury and metal halide dose in the arc-tube. Lamp electrical characteristics and light output stabilise in less than 4 minutes. During this period light output increases from zero to full output and colour approaches the final visual effect as each metallic element becomes vaporised.

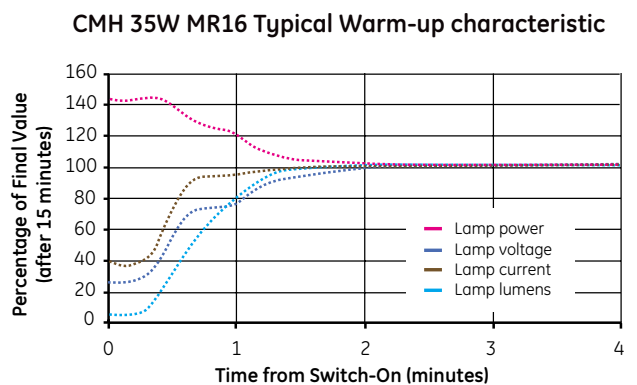
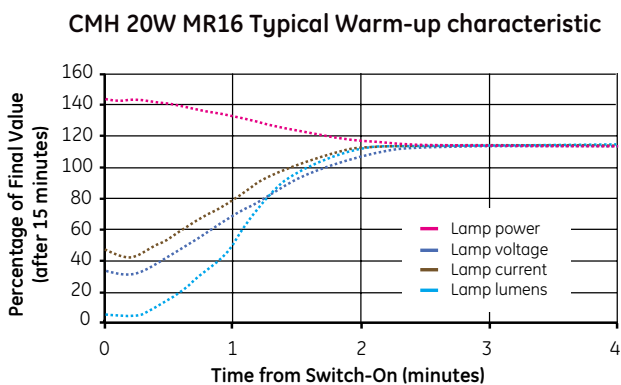

DIMMING

The dimming of ConstantColor CMH™ Precise™ MR16 lamps is not normally recommended. Large changes in lamp power alter the thermal characteristics of the lamp resulting in lamp colour shift and possible reduction in lamp through life survival.

FLICKER

Suitable electronic ballasts for ConstantColor CMH™ lamps provide switched dc operation in the 70-200 Hz range and eliminate perceptible flicker.

LAMP END-OF-LIFE CONDITIONS

The principal end-of-life failure mechanism for CMH™ lamps is arc tube leakage into the outer jacket. High operating temperature inside the arc-tube causes metal halide dose material to gradually corrode through the ceramic arc tube wall, eventually resulting at normal end-of-life in leakage of the filling gas and dose. Arc-tube leakage into the outer jacket can be observed by a sudden and significant lumen drop and a perceptible colour change (usually towards green).

The above situation can be accompanied by the so-called rectification phenomena. This occurs where a discharge is established between two mount-frame parts of different material and/or mass, causing asymmetry in the electrical characteristic of the resulting discharge current. Rectification can lead to overheating of the ballast, therefore to maintain safety use electronic ballast or system which can shut itself off if ballast overheating occurs.

LUMEN DEPRECIATION

All metal halide lamps experience a reduction in light output and slight increase in power consumption through life. Consequently there is an economic life when the efficacy of lamps fall to a level at which is advisable to replace lamps and restore illumination levels. Where a number of lamps are used within the same area it may be well worth considering a group lamp replacement programme to ensure uniform output from all the lamps.

END OF LIFE CYCLING

A possible condition can exist at end-of-life whereby lamp voltage rises to a value exceeding the voltage supplied by the control gear. In such a case the lamp extinguishes and on cooling restarts when the required ignition voltage falls to the actual pulse voltage provided by the gear. During subsequent warm-up the lamp voltage will again increase, causing extinction. This condition is known as end-of-life cycling. With electronic ballasts, cycling is unlikely.

Normally cycling is an indication that lamp end-of-life has been reached, but it can also occur when lamps are operated above their recommended temperature. Lamp voltage at 100 hours life should not increase by more than 5V when operating in the luminaire, when compared to the same lamp operating in free-air. A good luminaire design will limit lamp voltage rise to 3V.

It is good practice to replace lamps that have reached end-of-life as soon as possible after failure, to minimise electrical and thermal stress on control gear components

UV and damage to sensitive materials

The wall of the bulb, which is produced with specially developed 'UV Control' material, absorbs potentially harmful high energy UV radiation emitted by the ceramic arc-tube.

The use of UV control material allows the lamp to significantly reduce the risk of discolouration or fading of products. When illuminating light-sensitive materials or at high light levels, additional UV filtration is recommended. Luminaires should not be used if the front glass is broken or missing.

Although PET determines limits of human exposure to lamp UV, the risk of fading of merchandise due to UV can be quantified by a Damage Factor and a Risk of Fading. The risk of fading is simply the numerical product of the illuminance, exposure time and damage factor due to the light source.

Finally the selection of luminaire materials should take into consideration the UV emission. Current UV reduction types on the market are optimised for UV safety of human eye and skin exposure. However, luminaire materials may have different wavelength dependent response functions. Designers must take account of emission in each of the UV-A, UV-B and UV-C spectral ranges as well as material temperatures when designing luminaires.

Typical values for UV-A, UV-B and UV-C range radiation can be found in the table below.

UV and damage to sensitive materials

UV PET performance
Data from bare lamp

Product name	UV-C ¹ 200-280 nm	UV-B ¹ 280-315 nm	UV-A ¹ 315-400 nm	UVC/UVA	UVB/UVA	E_{eff}^2	PET (h)	Risk Group
CMH20MR16/830	0,0003	0,00005	0,0006	0,4609	0,0841	0,0009	900	Exempt
CMH35MR16/930	0,0001	0,00002	0,0004	0,1687	0,0421	0,0005	1765	Exempt
CMH35MR16/942	0,0001	0,00003	0,0011	0,0690	0,0248	0,0012	723	Exempt

¹ $\mu\text{W}/(\text{cm}^2)/500\text{ Lux}$

² $\text{mW}/(\text{m}^2 * \text{klx})$

Information for luminaire design

Electronic ballast operation

CMH 20W and CMH 35W have optimum performance on electronic gear.*

This provides many advantages:

- Flicker free light output
- Well controlled electronic ignition process
- Simple wiring for fixtures due to elimination of ignitor and PFC capacitor
- Reduces fixture weight
- Automatic sensing of failed lamps and shutdown
- Lower overall system power consumption

* For details of approved electronic ballasts for ConstantColor CMH™ lamps please consult your GE representative.

CMH 20W is designed only for operation on electronic gear

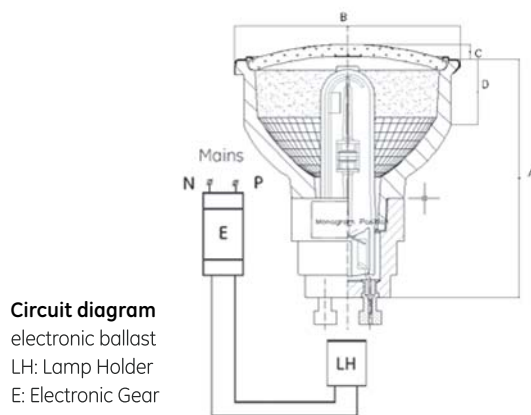

CONTROL GEAR AND ACCESSORIES

Electronic Ballasts

A range of GE electronic ballasts have been introduced to complement the 20 and 35W ConstantColor Ceramic Metal Halide lamps

Power controlled electronic ballasts suitable for operation of Ceramic Metal Halide lamps are available from various gear manufacturers. Please consult GE for up to date details of approved ballast types.

Advantages are:

- Good regulation against supply voltage variation
- Improved lamp colour consistency
- Elimination of lamp flicker
- Reduced weight of control gear
- Reduced electrical power losses
- Ballast noise reduced/eliminated
- Single piece compact unit
- Reduced wiring complexity in the luminaire



Safety warnings

Warning! The use of these products requires awareness of the following safety issues:

- Risk of electric shock - isolate from power supply before changing lamp
- Strong magnetic fields may impair lamp performance and worst case can lead to lamps shattering
- Risk of fire
- A damaged lamp emits UV radiation which may cause eye/skin injury

Caution

- Risk of burn when handling hot lamp
- Lamp may shatter and cause injury if broken
- Arc tube fill gas contains Kr-85

Always follow the lamp operation and handling instructions supplied.